

AVTECH ELECTROSYSTEMS LTD.

NANOSECOND WAVEFORM ELECTRONICS
SINCE 1975

P.O. BOX 265
OGDENSBURG, NY
U.S.A. 13669-0265
TEL: (315) 472-5270
FAX: (613) 226-2802

TEL: 1-800-265-6681
FAX: 1-800-561-1970

e-mail: info@avtechpulse.com
<http://www.avtechpulse.com/>

BOX 5120, LCD MERIVALE
OTTAWA, ONTARIO
CANADA K2C 3H4
TEL: (613) 226-5772
FAX: (613) 226-2802

INSTRUCTIONS

MODEL AV-107C-B

0 to 10 AMP, 0 to 60 V, 20 ns RISE TIME
LASER DIODE DRIVER
WITH IEEE 488.2 AND RS-232 CONTROL

SERIAL NUMBER: _____

WARRANTY

Avtech Electrosystems Ltd. warrants products of its manufacture to be free from defects in material and workmanship under conditions of normal use. If, within one year after delivery to the original owner, and after prepaid return by the original owner, this Avtech product is found to be defective, Avtech shall at its option repair or replace said defective item. This warranty does not apply to units which have been disassembled, modified or subjected to conditions exceeding the applicable specifications or ratings. This warranty is the extent of the obligation assumed by Avtech with respect to this product and no other warranty or guarantee is either expressed or implied.

TECHNICAL SUPPORT

Phone: 613-226-5772 or 1-800-265-6681

Fax: 613-226-2802 or 1-800-561-1970

E-mail: info@avtechpulse.com

World Wide Web: <http://www.avtechpulse.com>

TABLE OF CONTENTS

WARRANTY	2
TECHNICAL SUPPORT	2
TABLE OF CONTENTS	3
INTRODUCTION	5
-KMPA OPTION, -PW1 OPTION.....	6
SPECIFICATIONS	7
EUROPEAN REGULATORY NOTES	8
EC DECLARATION OF CONFORMITY.....	8
DIRECTIVE 2002/95/EC (RoHS).....	8
INSTALLATION	9
VISUAL CHECK.....	9
CONNECTING THE OUTPUT MODULE TO THE MAINFRAME.....	9
POWER RATINGS.....	9
CONNECTION TO THE POWER SUPPLY.....	9
PROTECTION FROM ELECTRIC SHOCK.....	10
ENVIRONMENTAL CONDITIONS.....	11
FUSES	12
AC FUSE REPLACEMENT.....	12
DC FUSE REPLACEMENT.....	13
FUSE RATINGS.....	13
MAINFRAME FRONT PANEL CONTROLS	14
REAR PANEL CONTROLS	16
OUTPUT MODULE CONTROLS AND CONNECTORS	18
GENERAL INFORMATION	19
BASIC TEST ARRANGEMENT.....	19
CURRENT MEASUREMENT.....	20
BASIC PULSE CONTROL.....	20
TRIGGER MODES.....	22
GATING MODES.....	23
LOAD PROTECTION	24
ATTACHING AND DETACHING LOADS.....	24
CHANGING PARAMETERS WHEN A LOAD IS ATTACHED.....	24

START-UP CHECK-LIST FOR LOCAL CONTROL.....	25
CALIBRATION ADJUSTMENTS - SOFTWARE PROCEDURES.....	27
ADJUSTING AMPLITUDE ACCURACY.....	27
PROGRAMMING YOUR PULSE GENERATOR.....	28
KEY PROGRAMMING COMMANDS.....	28
ALL PROGRAMMING COMMANDS.....	29
MECHANICAL INFORMATION.....	31
TOP COVER REMOVAL.....	31
RACK MOUNTING.....	31
ELECTROMAGNETIC INTERFERENCE.....	31
MAINTENANCE.....	32
REGULAR MAINTENANCE.....	32
CLEANING.....	32
WIRING DIAGRAMS.....	33
WIRING OF AC POWER.....	33
PCB 158H - LOW VOLTAGE DC POWER SUPPLY, 1/3.....	34
PCB 158H - LOW VOLTAGE DC POWER SUPPLY, 2/3.....	35
PCB 158H - LOW VOLTAGE DC POWER SUPPLY, 3/3.....	36
PCB 160B - HIGH VOLTAGE DC POWER SUPPLY.....	37
PCB 104D - KEYPAD / DISPLAY BOARD, 1/3.....	38
PCB 104D - KEYPAD / DISPLAY BOARD, 2/3.....	39
PCB 104D - KEYPAD / DISPLAY BOARD, 3/3.....	40
MAIN WIRING.....	41
APPENDIX A - LOW-VALUE, LOW-INDUCTANCE, HIGH-POWER RESISTORS.....	42
SUPPLIERS.....	42
PERFORMANCE CHECK SHEET.....	43

INTRODUCTION

The Model AV-107C-B pulse generator is designed for pulsing laser diode and other low impedance loads with rectangular pulses as high as 10 Amperes into load voltages up to 60V, with 20 ns rise and fall times. The pulse repetition frequency can vary from 1 Hz to 5 kHz, and pulse widths can vary from 100 ns to 1 us (or optionally 20 us). The current and voltage polarities depend on the model number:

- "-P" units: 0 to +10 A amplitude, 0 to +60V compliance
- "-N" units: 0 to -10 A amplitude, 0 to -60V compliance
- "-PN" units: 0 to ± 10 A amplitude, 0 to +60V compliance for positive output, and 0 to -60V compliance for negative output.

The Model AV-107C-B pulse generator is a current pulser. The current amplitude is largely independent of the load voltage. The load voltage must not exceed 60V.

The AV-107C-B system consists of an instrument mainframe and an output module (the AV-107C-P-PG for positive units, the AV-107C-N-PG for negative units. Dual polarity units have both output modules.) The output module connects to the mainframe using two cables: a 25-conductor detachable cable that carries the control signals, and a single-conductor shielded detachable RG-58 cable carries the high voltage power supply (+100V or -100V).

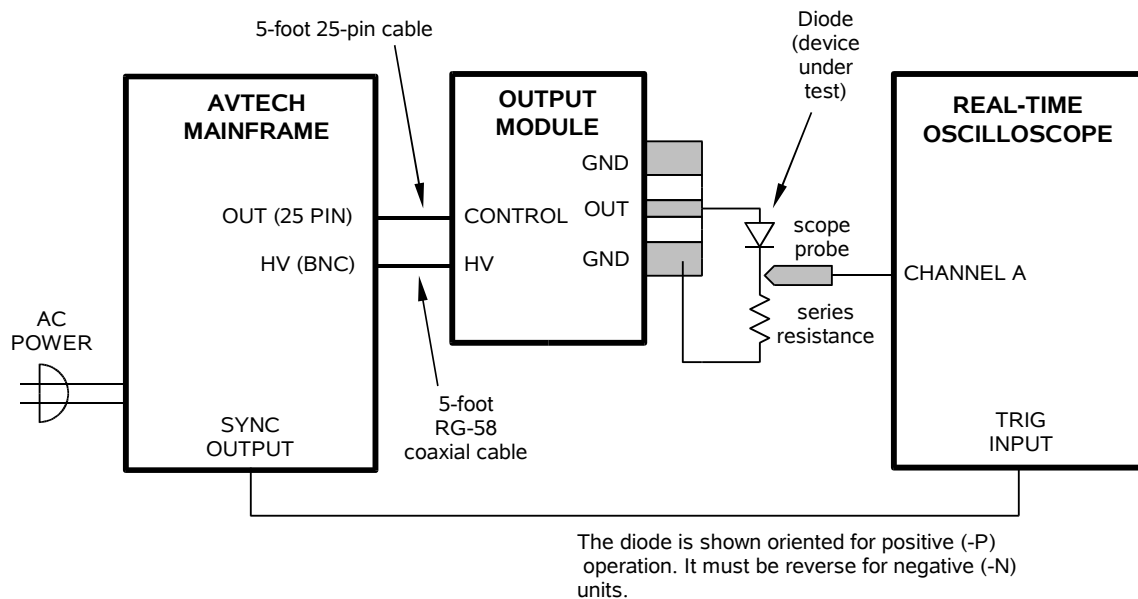

The loads can be connected (soldered) to the microstrip transmission line that protrudes from the output module. The lead lengths must not exceed several centimeters or severe inductive voltage spikes will result (as predicted by Lenz's Law.)

For instruments with the "-M" option, a current monitor output is present on the output module.

The AV-107C-B has two amplitude ranges, of 0 to 1A and 1 to 10A, allowing the instrument to be used at both moderate and high current levels. (The instrument automatically selects the appropriate range based on the amplitude setting.)

The AV-107C-B can be controlled from the front panel, or via a computer connected to the IEEE 488.2-compliant GPIB port, or the RS-232 serial port.

-KMPA OPTION, -PW1 OPTION

Units with the -KMPA options or the -PW1 option have an extended maximum pulse width of 20 us. The maximum duty cycle remains at 0.5%.

SPECIFICATIONS

Model:	AV-107C-B
GPIB, RS-232 control:	Standard on -B units.
Amplitude: -P units: -N units: -PN units:	0 to +10 Amperes 0 to -10 Amperes 0 to ± 10 Amperes
Pulse width:	100 ns to 1 μ s (with -KMPA or -PW1 option: 100 ns to 20 μ s)
Rise time, fall time:	≤ 20 ns
Duty Cycle:	0.5% maximum
PRF:	1 Hz to 5 kHz
Current regulation:	Load voltage change from 0 to 60 Volts: $\leq 5\%$
Load voltage range: -P units: -N units: -PN units:	0 to +60 Volts 0 to -60 Volts 0 to +60 Volts for positive output, 0 to -60 Volts for negative output
Propagation delay, (Jitter):	≤ 100 ns, (± 100 ps $\pm 0.03\%$ of sync delay, Ext trig in to pulse out)
Ext. trigger in:	+ 5 Volts, 50 ns or wider (TTL)
Sync delay: (sync to pulse out)	0 to ± 1 s
Sync output:	+ 3 Volt, 100 ns, will drive 50 Ohm loads
Gate input:	Synchronous or asynchronous, active high or low, switchable. Suppresses triggering when active.
Connectors:	Out: Solder terminals Trig: BNC Sync: BNC Gate: BNC HV: SMA
Power requirements:	100 - 240 Volts, 50 - 60 Hz
Dimensions:	Mainframe: 100 x 215 x 375 mm (3.9" x 8.5" x 14.8") Output module: 109 x 66 x 43 mm (4.3" x 2.6" x 1.7")
Temperature range:	+5°C to +40°C

EUROPEAN REGULATORY NOTES

EC DECLARATION OF CONFORMITY

We

Avtech Electrosystems Ltd.
P.O. Box 5120, LCD Merivale
Ottawa, Ontario
Canada K2C 3H4

declare that this pulse generator meets the intent of Directive 89/336/EEC for Electromagnetic Compatibility. Compliance pertains to the following specifications as listed in the official Journal of the European Communities:

EN 50081-1 Emission

EN 50082-1 Immunity

and that this pulse generator meets the intent of the Low Voltage Directive 72/23/EEC as amended by 93/68/EEC. Compliance pertains to the following specifications as listed in the official Journal of the European Communities:

EN 61010-1:2001 Safety requirements for electrical equipment for measurement, control, and laboratory use



DIRECTIVE 2002/95/EC (RoHS)

This instrument is exempt from Directive 2002/95/EC of the European Parliament and of the Council of 27 January 2003 on the Restriction of the use of certain Hazardous Substances (RoHS) in electrical and electronic equipment. Specifically, Avtech instruments are considered "Monitoring and control instruments" (Category 9) as defined in Annex 1A of Directive 2002/96/EC. The Directive 2002/95/EC only applies to Directive 2002/96/EC categories 1-7 and 10, as stated in the "Article 2 - Scope" section of Directive 2002/95/EC.

INSTALLATION

VISUAL CHECK

After unpacking the instrument, examine to ensure that it has not been damaged in shipment. Visually inspect all connectors, knobs, liquid crystal displays (LCDs), and the handles. Confirm that a power cord, a GPIB cable, and two instrumentation manuals (this manual and the “Programming Manual for -B Instruments”) are with the instrument. If the instrument has been damaged, file a claim immediately with the company that transported the instrument.

CONNECTING THE OUTPUT MODULE TO THE MAINFRAME

The output module and the mainframe should be connected together as shown in the “Basic Test Arrangement” section of this manual. One end of the 25 pin cable mates to the multi-pin “OUT” connector on the rear panel of the mainframe, and the other end mates to the “CONTROL” connector on the output module. The black RG-58 cable connects to the “HV” SMA connectors. Note that the output module should be attached to a heatsink capable of dissipating 5 Watts if minimizing long-term drift of the output amplitude is critical.

Replacement 25 pin cables may be ordered from L-Com (<http://www.l-com.com>), using the special-order part number SP11472.

Replacement RG-58 cables may be ordered from Pasternack Enterprises (<http://www.pasternack.com>) using the standard part number PE3369-60.

POWER RATINGS

This instrument is intended to operate from 100 - 240 V, 50 - 60 Hz.

The maximum power consumption is 57 Watts. Please see the “FUSES” section for information about the appropriate AC and DC fuses.

This instrument is an “Installation Category II” instrument, intended for operation from a normal single-phase supply.

CONNECTION TO THE POWER SUPPLY

An IEC-320 three-pronged recessed male socket is provided on the back panel for AC power connection to the instrument. One end of the detachable power cord that is supplied with the instrument plugs into this socket. The other end of the detachable power cord plugs into the local mains supply. Use only the cable supplied with the instrument. The mains supply must be earthed, and the cord used to connect the

instrument to the mains supply must provide an earth connection. (The supplied cord does this.)

 Warning: Failure to use a grounded outlet may result in injury or death due to electric shock. This product uses a power cord with a ground connection. It must be connected to a properly grounded outlet. The instrument chassis is connected to the ground wire in the power cord.

The table below describes the power cord that is normally supplied with this instrument, depending on the destination region:

Destination Region	Description	Manufacturer	Part Number
Continental Europe	European CEE 7/7 "Schuko" 230V, 50Hz	Volex (http://www.volex.com)	17850-C3-326
United Kingdom	BS 1363, 230V, 50Hz	Volex (http://www.volex.com)	17962-C3-10
Switzerland	SEV 1011, 230V, 50Hz	Volex (http://www.volex.com)	2102H-C3-10
Israel	SI 32, 220V, 50Hz	Volex (http://www.volex.com)	2115H-C3-10
North America, and all other areas	NEMA 5-15, 120V, 60 Hz	Volex (http://www.volex.com)	17250-B1-10
		Qualtek (http://www.qualtekusa.com)	312007-01

PROTECTION FROM ELECTRIC SHOCK

 Operators of this instrument must be protected from electric shock at all times. The owner must ensure that operators are prevented access and/or are insulated from every connection point. In some cases, connections must be exposed to potential human contact. Operators must be trained to protect themselves from the risk of electric shock. This instrument is intended for use by qualified personnel who recognize shock hazards and are familiar with safety precautions required to avoid possibly injury. In particular, operators should:

- 1) Keep exposed high-voltage wiring to an absolute minimum.
- 2) Wherever possible, use shielded connectors and cabling.
- 3) Connect and disconnect loads and cables only when the instrument is turned off.
- 4) Keep in mind that all cables, connectors, oscilloscope probes, and loads must have an appropriate voltage rating.
- 5) Do not attempt any repairs on the instrument, beyond the fuse replacement procedures described in this manual. Contact Avtech technical support (see page 2 for contact information) if the instrument requires servicing. Service is to be performed solely by qualified service personnel.

ENVIRONMENTAL CONDITIONS

This instrument is intended for use under the following conditions:

1. indoor use;
2. altitude up to 2 000 m;
3. temperature 5 °C to 40 °C;
4. maximum relative humidity 80 % for temperatures up to 31 °C decreasing linearly to 50 % relative humidity at 40 °C;
5. Mains supply voltage fluctuations up to ± 10 % of the nominal voltage;
6. no pollution or only dry, non-conductive pollution.

FUSES

This instrument contains four fuses. All are accessible from the rear-panel. Two protect the AC prime power input, and two protect the internal DC power supplies. The locations of the fuses on the rear panel are shown in the figure below:

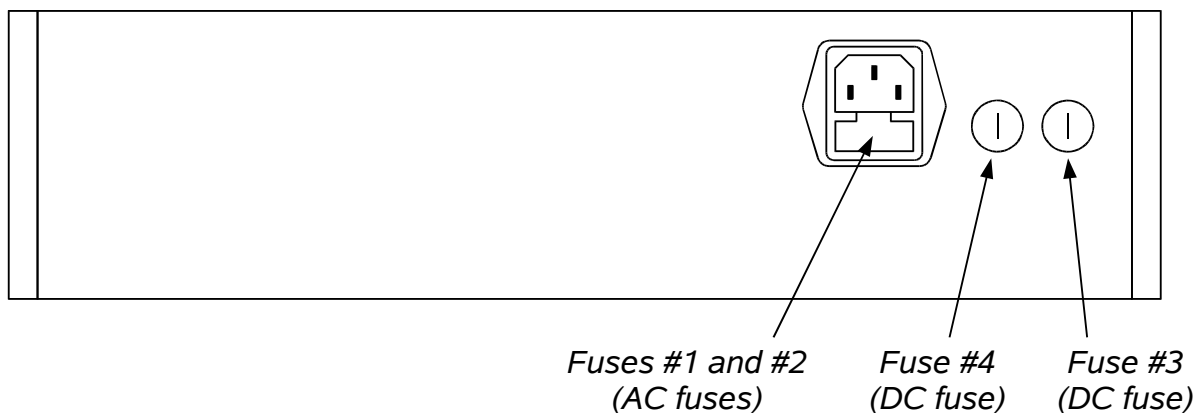

AC FUSE REPLACEMENT

To physically access the AC fuses, the power cord must be detached from the rear panel of the instrument. The fuse drawer may then be extracted using a small flat-head screwdriver, as shown below:

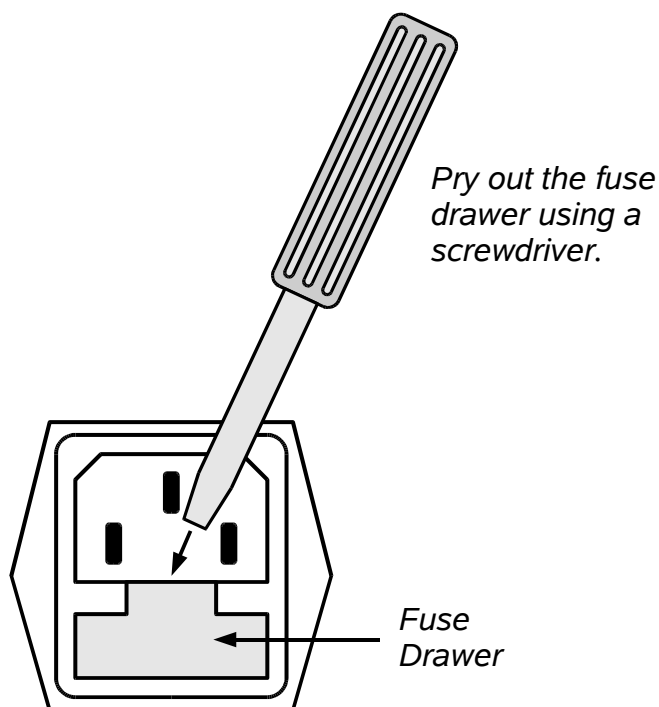

DC FUSE REPLACEMENT

The DC fuses may be replaced by inserting the tip of a flat-head screwdriver into the fuse holder slot, and rotating the slot counter-clockwise. The fuse and its carrier will then pop out.

FUSE RATINGS

The following table lists the required fuses:

Fuses	Nominal Mains Voltage	Rating	Case Size	Manufacturer's Part Number (Wickmann)	Distributor's Part Number (Digi-Key)
#1, #2 (AC)	100-240V	0.5A, 250V, Time-Delay	5×20 mm	1950500000	WK5041-ND
#3 (DC)	N/A	1.6A, 250V, Time-Delay	5×20 mm	1951160000	WK5053-ND
#4 (DC)	N/A	0.5A, 250V, Time-Delay	5×20 mm	1950500000	WK5041-ND

The fuse manufacturer is Wickmann (<http://www.wickmann.com/>).

Replacement fuses may be easily obtained from Digi-Key (<http://www.digikey.com/>) and other distributors.

MAINFRAME FRONT PANEL CONTROLS

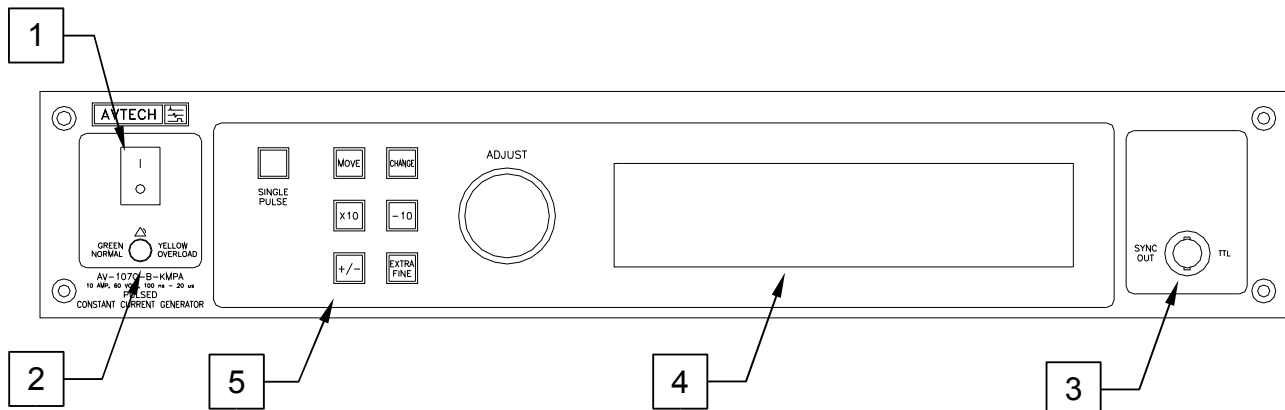

1. POWER Switch. This is the main power switch. When turning the instrument on, there may be a delay of several seconds before the instrument appears to respond.
2. OVERLOAD Indicator. When the instrument is powered, this indicator is normally green, indicating normal operation. If this indicator is yellow, an internal automatic overload protection circuit has been tripped. If the unit is overloaded (by operating at an exceedingly high duty cycle or by operating into a very low impedance), the protective circuit will disable the output of the instrument and turn the indicator light yellow. The light will stay yellow (i.e. output disabled) for about 5 seconds after which the instrument will attempt to re-enable the output (i.e. light green) for about 1 second. If the overload condition persists, the output will be disabled again (i.e. light yellow) for another 5 seconds. If the overload condition has been removed, the instrument will resume normal operation.

This overload indicator may flash yellow briefly at start-up. This is not a cause for concern.

3. SYNC OUT. This connector supplies a SYNC output that can be used to trigger other equipment, particularly oscilloscopes. This signal leads (or lags) the main output by a duration set by the "DELAY" controls and has an approximate amplitude of +3 Volts to $R_L > 50\Omega$ with a pulse width of approximately 100 ns.
4. LIQUID CRYSTAL DISPLAY (LCD). This LCD is used in conjunction with the keypad to change the instrument settings. Normally, the main menu is displayed, which lists the key adjustable parameters and their current values. The "Programming Manual for -B Instruments" describes the menus and submenus in detail.

5. KEYPAD.

Control Name	Function
MOVE	This moves the arrow pointer on the display.
CHANGE	This is used to enter the submenu, or to select the operating mode, pointed to by the arrow pointer.
×10	If one of the adjustable numeric parameters is displayed, this increases the setting by a factor of ten.
÷10	If one of the adjustable numeric parameters is displayed, this decreases the setting by a factor of ten.
+/-	If one of the adjustable numeric parameters is displayed, and this parameter can be both positive or negative, this changes the sign of the parameter.
EXTRA FINE	This changes the step size of the ADJUST knob. In the extra-fine mode, the step size is twenty times finer than in the normal mode. This button switches between the two step sizes.
ADJUST	This large knob adjusts the value of any displayed numeric adjustable values, such as frequency, pulse width, etc. The adjust step size is set by the "EXTRA FINE" button. When the main menu is displayed, this knob can be used to move the arrow pointer.

REAR PANEL CONTROLS

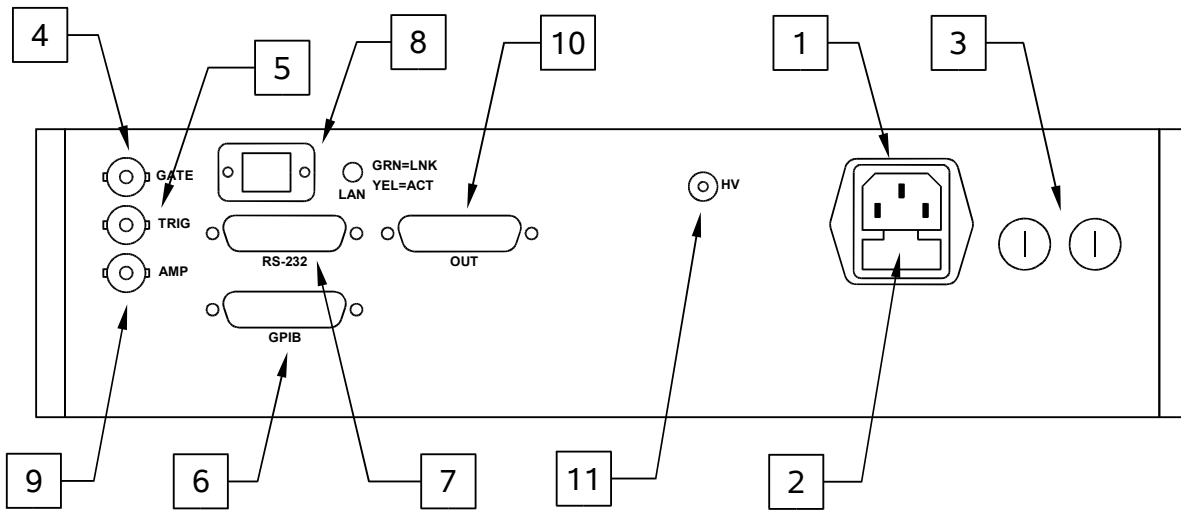

1. AC POWER INPUT. An IEC-320 C14 three-pronged recessed male socket is provided on the back panel for AC power connection to the instrument. One end of the detachable power cord that is supplied with the instrument plugs into this socket.
2. AC FUSE DRAWER. The two fuses that protect the AC input are located in this drawer. Please see the “FUSES” section of this manual for more information.
3. DC FUSES. These two fuses protect the internal DC power supplies. Please see the “FUSES” sections of this manual for more information.
4. GATE. This TTL-level (0 and +5V) logic input can be used to gate the triggering of the instrument. This input can be either active high or active low, depending on the front panel settings or programming commands. (The instrument triggers normally when this input is unconnected). When set to active high mode, this input is pulled-down to ground by a 1 k Ω resistor. When set to active low mode, this input is pulled-up to +5V by a 1 k Ω resistor.
5. TRIG. This TTL-level (0 and +5V) logic input can be used to trigger the instrument, if the instrument is set to triggering externally. The instrument triggers on the rising edge of this input. The input impedance of this input is 1 k Ω . (Depending on the length of cable attached to this input, and the source driving it, it may be desirable to add a coaxial 50 Ohm terminator to this input to provide a proper transmission line termination. The Pasternack (www.pasternack.com) PE6008-50 BNC feed-thru 50 Ohm terminator is suggested for this purpose.)

When triggering externally, the instrument can be set such that the output pulse width tracks the pulse width on this input, or the output pulse width can be set independently.

6. GPIB Connector. A standard GPIB cable can be attached to this connector to allow the instrument to be computer-controlled. See the "Programming Manual for -B Instruments" for more details on GPIB control.
7. RS-232 Connector. A standard serial cable with a 25-pin male connector can be attached to this connector to allow the instrument to be computer-controlled. See the "Programming Manual for -B Instruments" for more details on RS-232 control.
8. LAN Connector and Indicator. (Optional feature. Present on -TNT units only.) The -TNT option "Internet-enables" Avtech pulse generators by adding this standard Ethernet port to the rear panel, in addition to the IEEE-488.2 GPIB and RS-232 ports normally found on "-B" units. Commands are sent using the standard Telnet protocol. The SCPI-compliant command set is the same as that used for GPIB and RS-232 control. The -TNT option uses the Dynamic Host Configuration Protocol (DHCP) to obtain its network address. A DHCP server must be present on the local network for the -TNT option to operate properly.
9. AMP Connector. (Optional feature. Present on -EA units only.) The output amplitude can be set to track the voltage on this input. Zero Volts in corresponds to zero amplitude output, and +10V in corresponds to maximum amplitude out. This mode is activated by selecting "Ext Control" on the front-panel amplitude menu, or with the "source:voltage external" command.
10. OUT. The 25-pin cable from the output module is connected to this connector.
11. HV SMA Connector. The shielded RG-58 cable from the output module is connected to this connector. This carries the high-voltage power supply (+100V or -100V, depending on the output polarity) to the output module.

OUTPUT MODULE CONTROLS AND CONNECTORS

OUT Microstrip Line

The main output is provided on the center conductor of the microstrip board protruding from the output module. The outer two conductors, as well as the reverse side of the microstrip board are connected to ground.

A typical connection scheme (for positive output current) is shown below:

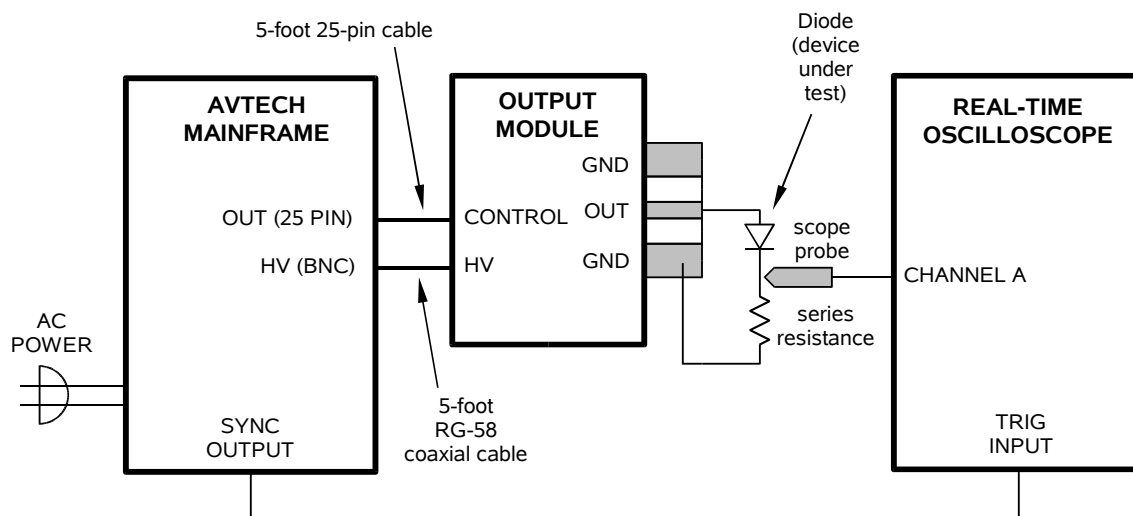

The diode is shown oriented for positive (-P) operation. It must be reverse for negative (-N) units.

The load should be connected between the OUT and GND terminals using very short leads (<5.0 cm, and preferably < 0.5 cm). Severe inductive voltage spikes will result from any series inductance (Lenz's Law). Take care to ensure that during soldering the OUT conductor is not shorted to the chassis. Use minimal heat when soldering to avoid delaminating the metal pads.

If the load cannot be placed directly on the output terminals of the -PG module, the AV-LZ lines should be used between the -PG module and the load (see the Avtech AV-LZ data sheet, available at www.avtechpulse.com).

GENERAL INFORMATION

BASIC TEST ARRANGEMENT

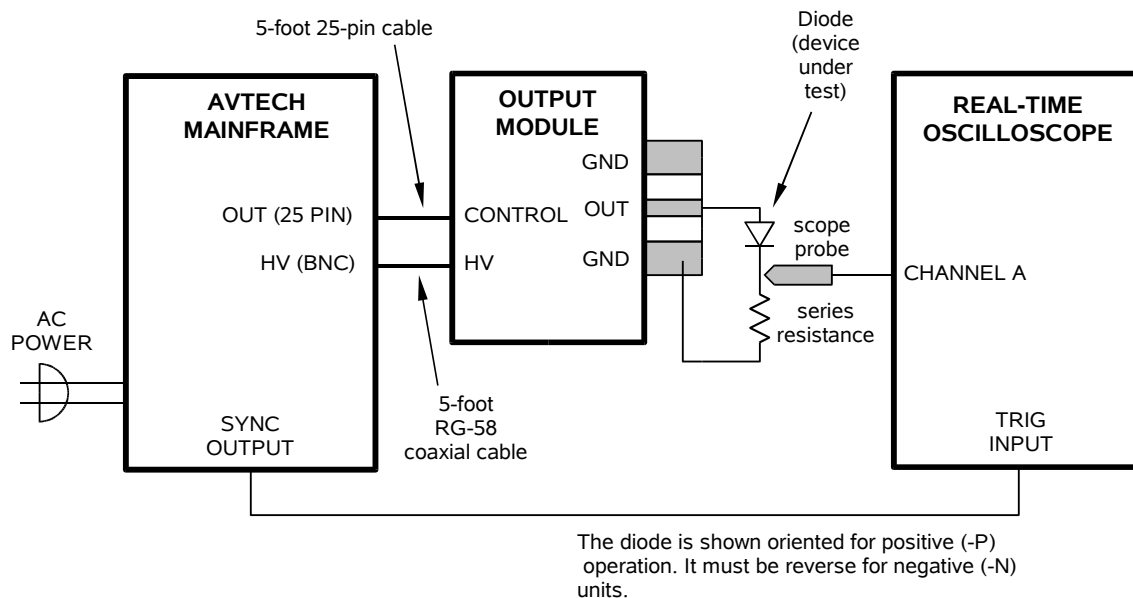

The equipment should be connected in the general fashion shown above (see page 8 also). For dual-polarity instruments, only one output module is connected at a time.

Output modules should always be connected to the mainframe **BEFORE power is applied**.

Proper choice of test resistance is important. It is essential that the resistive test load be low-inductance. (Wirewound resistors are not acceptable, unless many are connected together in parallel.) The power dissipated in the resistor is given by

$$P = I^2 \times R \times PW / T$$

where "I" is the current, "R" is the resistance, "PW" is the pulse width, and "T" is the pulse period (1/frequency).

The power rating of the resistance should exceed this average power rating by a large margin. Beware that some low-value resistors exhibit a significant temperature-dependence, even when the average power dissipated is below the resistor's power rating. This is particularly true if the peak power exceeds the resistor's power rating.

Factory tests are conducted with a 3.3Ω load capable of dissipating at least 6 W. Higher load resistance values may be used but the output voltage must be limited to 60V or less. See the appendix for a list of suitable resistors.

CURRENT MEASUREMENT

Measuring current is more difficult than measuring voltage. There are four basic approaches to measuring pulsed current:

1. Rely on the accuracy of the amplitude setting (typically 5%), as displayed on the LCD display.
2. Use a high-performance current transformer, such as a Pearson 2878 (<http://www.pearsonelectronics.com>), the Integrated Sensor Technologies 711S (<http://www.isensortech.com>), or the Tektronix CT-2 (<http://www.tek.com>). The output voltage of the transformer is proportional to the sensed current. It may be necessary to introduce a significant lead length (i.e., inductance) to pass the conductor through the transformer.
3. Use a low-resistance, low-inductance, current-sensing resistor connected in series with the load. To minimize inductance, it is usually wise to connect several resistors in parallel. Beware that wirewound resistors usually have far too much inductance to be useful as current-sensing resistors.
4. The AV-107C-B includes a monitor output connector on the output module.

The monitor output should be terminated with a 50 Ohm load. On standard units, the monitor output voltage (V_M) is related to the load current (I_L) by:

$$V_M \approx I_L \times 1.0 \text{ Amp/Volt, approximately}$$

Units with the -KMPA or -PW1 options have two monitor outputs. The uppermost monitor output connector is the output of a high-speed AC-coupled current transformer. It is only useful for pulse widths of 1 us or less. At wider pulse widths, the transformer will saturate and the monitor output will cease to be accurate. This monitor output accurately reproduces the rising edge of the current pulse. The lower monitor output connector is the output of a slower AC-coupled current transformer. It operates correctly up to the maximum rated pulse width of 20 us. However, it is not fast enough to accurately measure the rising and falling edges. For both outputs, the monitor output voltage (V_M) is related to the load current (I_L) by:

$$V_M \approx I_L \times 0.4 \text{ Amp/Volt, approximately}$$

These ratios are only valid when the monitor output is terminated with a 50 Ohm load.

BASIC PULSE CONTROL

This instrument can be triggered by its own internal clock or by an external TTL trigger signal. In either case, two output channels respond to the trigger: OUT and SYNC. The OUT channel is the signal that is applied to the device under test. Its amplitude and

pulse width are variable. The SYNC pulse is a fixed-width TTL-level reference pulse used to trigger oscilloscopes or other measurement systems. When the delay is set to a positive value the SYNC pulse precedes the OUT pulse.

These pulses are illustrated below, assuming internal triggering, positive delay, and a positive output:

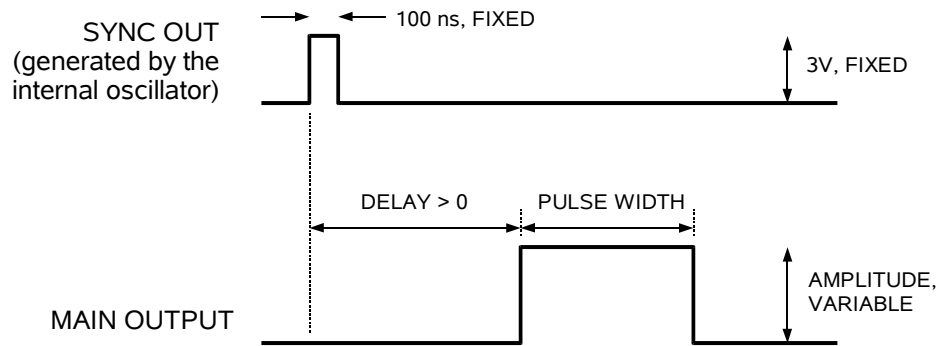

Figure A

If the delay is negative, the order of the SYNC and OUT pulses is reversed:

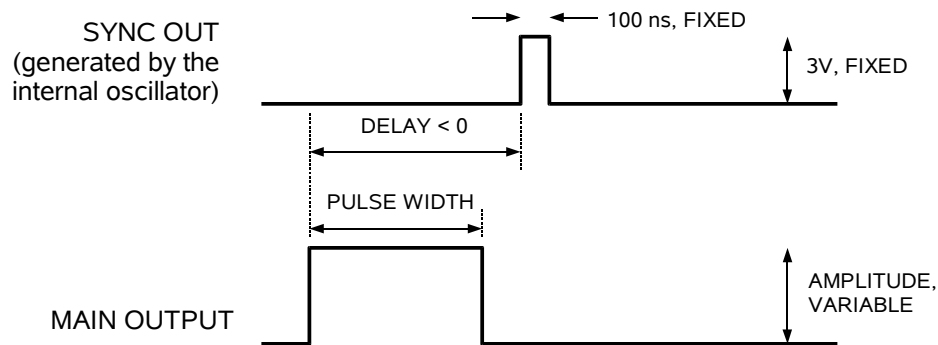

Figure B

The next figure illustrates the relationship between the signal when an external TTL-level trigger is used:

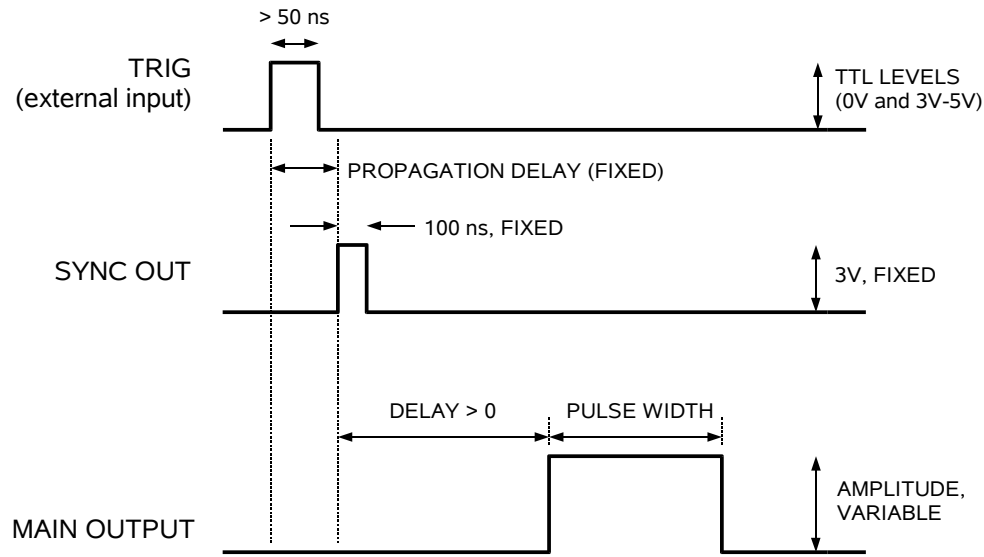

Figure C

As before, if the delay is negative, the order of the SYNC and OUT pulses is reversed.

The delay, pulse width, and frequency (when in the internal mode), of the OUT pulse can be varied with front panel controls or via the GPIB or RS-232 computer interfaces.

TRIGGER MODES

This instrument has four trigger modes:

- Internal Trigger: the instrument controls the trigger frequency, and generates the clock internally.
- External Trigger: the instrument is triggered by an external TTL-level clock on the back-panel TRIG connector.
- Manual Trigger: the instrument is triggered by the front-panel "SINGLE PULSE" pushbutton.
- Hold Trigger: the instrument is set to not trigger at all.

These modes can be selected using the front panel trigger menu, or by using the appropriate programming commands. (See the "Programming Manual for -B Instruments" for more details.)

GATING MODES

Triggering can be suppressed by a TTL-level signal on the rear-panel GATE connector. The instrument can be set to stop triggering when this input high or low, using the front-panel gate menu or the appropriate programming commands. This input can also be set to act synchronously or asynchronously. When set to asynchronous mode, the GATE will disable the output immediately. Output pulses may be truncated. When set to synchronous mode, the output will complete the full pulse width if the output is high, and then stop triggering. No pulses are truncated in this mode.

LOAD PROTECTION

This instrument is designed to pulse resistive and diode loads and will exhibit a large output spike when used to drive a load with significant inductance (as predicted by LENZ'S LAW). For this reason the load should be connected to the output using low inductance leads (as short as possible and as heavy a gauge as possible).

The voltage developed across an inductance L (in Henries), when the current is changing at a rate given by di_{LOAD}/dt (in Amps/sec), is $V_{SPIKE} = L \times di_{LOAD}/dt$.

Some load inductance is unavoidable. As a result, the output voltage waveform (measured across a resistance) will have some distortion on the leading edge, as shown:

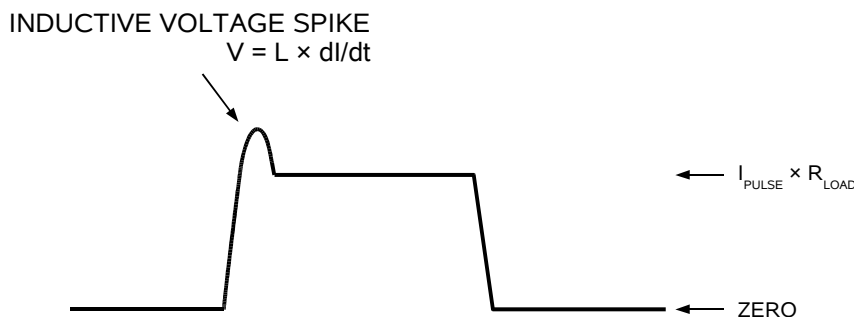

Attaching a current transformer (for measuring current waveforms) can add significant inductance, because of the necessary wire length (1 to 3 inches, typically) that must be fed through the transformer. This inductance may degrade the output current rise time.

ATTACHING AND DETACHING LOADS

To avoid damaging the loads connected to main outputs, the loads should only be connected to or removed from the instrument when the instrument is off. Do not connect loads when the instrument is on and the output amplitude is not zero. This can cause sparking.

CHANGING PARAMETERS WHEN A LOAD IS ATTACHED

If your load is easily damaged, the amplitude should be reduced to zero before changing the trigger source, frequency, pulse width, or other pulse parameters. This protects the loads from possible short transient effects.

START-UP CHECK-LIST FOR LOCAL CONTROL

- 1) The instruction manual has been studied thoroughly.
- 2) The “Local Control” section of the “Programming Manual for -B Instruments” has been studied thoroughly.
- 3) The output module is connected to the mainframe as shown in the “Basic Test Arrangement” section. (The output module should always be connected to the mainframe BEFORE power is applied.)
- 4) The load is connected to the output module microstrip output. The center conductor is the output line, and the two outer conductors are connected to ground. For initial testing, it is recommended that a resistive load be used. Factory tests are conducted using a 3.3 Ohm, 6 Watt resistive load. See the appendix for a list of suitable resistors.

These tests may also be conducted using a diode load. In this case, for -P units (or when using the positive output module of a “-PN” unit), the diode anode should be connected to the wide center microstrip on the output circuit board, and the cathode should be connected to either of the narrow outer microstrips. For -N units (or when using the negative output module of a “-PN” unit), the diode cathode should be connected to the wide center microstrip on the output circuit board, and the anode should be connected to either of the narrow outer microstrips.

- 5) Attach an oscilloscope probe to the load.
- 6) Turn on the prime power to the mainframe. The main menu will appear.
- 7) The arrow pointer should be pointing at the frequency menu item. If it is not, press the MOVE button until it is.
- 8) Press the CHANGE button. The frequency submenu will appear. Rotate the ADJUST knob until the frequency is set at the desired setting. The arrow pointer should be pointing at the “Internal” choice. If it is not, press MOVE until it is.
- 9) Press CHANGE to return to the main menu.
- 10) Press the MOVE button to move the arrow pointer to the pulse width menu item. Press CHANGE to bring up the pulse width submenu, and rotate the ADJUST knob until the pulse width is set at the desired setting. The arrow pointer should be pointing at the “Normal” choice. If it is not, press MOVE until it is. Press CHANGE to return to the main menu.
- 11) Press the MOVE button to move the arrow pointer is pointing at the output item. Press CHANGE to bring up the output submenu. The arrow pointer should be

initially be pointing at the “Output Off” choice. Press MOVE so that the arrow pointer is pointing at the “Output On” choice. (The mainframe is now supplying a trigger to the output module.) Press CHANGE to return to the main menu.

- 12) Press the MOVE button to move the arrow pointer to the amplitude menu item. Press CHANGE to bring up the amplitude submenu, and rotate the ADJUST knob until the amplitude is set at the desired setting. A rectangular pulse should appear on the scope and the amplitude should increase as the ADJUST knob is rotated.
- 13) Observe the pulse width and pulse period on the scope and confirm that the peak current does not exceed 10 Amps.
- 14) Adjust pulse width, pulse period (i.e. PRF) and amplitude to obtain the desired settings.
- 15) If additional assistance is required:

Tel: (613) 226-5772, Fax: (613) 226-2802
Email: info@avtechpulse.com

CALIBRATION ADJUSTMENTS - SOFTWARE PROCEDURES

ADJUSTING AMPLITUDE ACCURACY

The AV-107C-B has two amplitude ranges: 0 to 1A, and 1A to 10A, approximately. The calibration of each range can be adjusted by a few percent if necessary.

If it is found that the output amplitude settings (as set by the front-panel controls or programming commands) do not agree exactly with measured values of amplitude (i.e., by examining the output on an oscilloscope) in one of these ranges, the amplitude calibration can be updated using software commands.

The following procedure is suggested:

- 6) Connect a precision, high-power resistive load to the output. (As an example, suppose 3Ω is used.)
- 7) Connect the pulse generator to a computer using the GPIB or RS232 ports.
- 8) Turn on the pulse generator, and set the time controls (frequency, delay, pulse width) to typical values.
- 9) Turn on the outputs.
- 10) Set the output amplitude to 80% of the maximum current for that range. For instance, if the 0 to 10A range requires calibration, set the amplitude to 8A.
- 11) Observe the voltage across the load. (Using the 3Ω example, suppose that 21V is observed.) From this, calculate the measured current (7.0 A in this example).
- 12) Send the measured value to the instrument using the following command:

```
diag:ampl:cal 7.0
```

The internal software compares the supplied measured value to the programmed value, and adjusts the internal calibration data to null out any differences.

- 13) Observe the voltage across the load again. The amplitude setting should now agree with the measured value.

PROGRAMMING YOUR PULSE GENERATOR

KEY PROGRAMMING COMMANDS

The “Programming Manual for -B Instruments” describes in detail how to connect the pulse generator to your computer, and the programming commands themselves. A large number of commands are available; however, normally you will only need a few of these. Here is a basic sample sequence of commands that might be sent to the instrument after power-up:

*rst	(resets the instrument)
trigger:source internal	(selects internal triggering)
frequency 10 Hz	(sets the frequency to 10 Hz)
pulse:width 500 ns	(sets the pulse width to 500 ns)
pulse:delay 200 ns	(sets the delay to 200 ns)
output on	(turns on the output)
source:current 7 A	(sets the current amplitude to 7 amperes)

For triggering a single event, this sequence would be more appropriate:

*rst	(resets the instrument)
trigger:source hold	(turns off all triggering)
pulse:width 500 ns	(sets the pulse width to 500 ns)
output on	(turns on the output)
source:current 7 A	(sets the current amplitude to 7 amperes)
trigger:source immediate	(generates a single non-repetitive trigger event)
trigger:source hold	(turns off all triggering)
output off	(turns off the output)

To set the instrument to trigger from an external TTL signal applied to the rear-panel TRIG connector, use:

*rst	(resets the instrument)
trigger:source external	(selects external triggering)
pulse:width 500 ns	(sets the pulse width to 500 ns)
pulse:delay 200 ns	(sets the delay to 200 ns)
source:current 7 A	(sets the current amplitude to 7 amperes)
output on	(turns on the output)

These commands will satisfy 90% of your programming needs.

ALL PROGRAMMING COMMANDS

For more advanced programmers, a complete list of the available commands is given below. These commands are described in detail in the “Programming Manual for -B Instruments”. (Note: this manual also includes some commands that are not implemented in this instrument. They can be ignored.)

<u>Keyword</u>	<u>Parameter</u>	<u>Notes</u>
DIAGnostic:		
:AMPLitude		
:CALibration:	<numeric value>	[no query form]
LOCAL		
OUTPut:		
:[STATE]	<boolean value>	
:PROTection		
:TRIPped?		[query only]
REMOTE		
[SOURce]:		
:FREQuency		
[:CW FIXed]	<numeric value>	
[SOURce]:		
:CURRent		
[:LEVel]		
[:IMMediate]		
[:AMPLitude]	<numeric value>	
:PROTection		
:TRIPped?		[query only]
[SOURce]:		
:PULSe		
:PERiod	<numeric value>	
:WIDTh	<numeric value>	
:DCYCLE	<numeric value>	
:HOLD	WIDTh DCYCLE	
:DELay	<numeric value>	
:GATE		
:TYPE	ASync SyNc	
:LEVel	HIgh LOw	
STATUS:		
:OPERation		
:[EVENT]?		[query only, always returns "0"]
:CONDition?		[query only, always returns "0"]
:ENABle	<numeric value>	[implemented but not useful]
:QUEStionable		
:[EVENT]?		[query only, always returns "0"]
:CONDition?		[query only, always returns "0"]
:ENABle	<numeric value>	[implemented but not useful]
SYSTem:		
:COMMunicate		
:GPIB		
:ADDReSS	<numeric value>	
:SERial		
:CONTRol		
:RTS	ON IBFull RFR	
:[RECeive]		
:BAUD	1200 2400 4800 9600	

:BITS	7 8	
:ECHO	<boolean value>	
:PARity		
:[TYPE]	EVEN ODD NONE	
:SBITS	1 2	
:ERRor		
:[NEXT]?		[query only]
:COUNT?		[query only]
:VERSion?		[query only]
TRIGger:		
:SOURce	INTernal EXTernal MANual HOLD IMMEDIATE	
*CLS		[no query form]
*ESE	<numeric value>	
*ESR?		[query only]
*IDN?		[query only]
*OPC		
*SAV	0 1 2 3	[no query form]
*RCL	0 1 2 3	[no query form]
*RST		[no query form]
*SRE	<numeric value>	
*STB?		[query only]
*TST?		[query only]
*WAI		[no query form]

MECHANICAL INFORMATION

TOP COVER REMOVAL

If necessary, the interior of the instrument may be accessed by removing the four Phillips screws on the top panel. With the four screws removed, the top cover may be slid back (and off).

 Always disconnect the power cord and allow the instrument to sit unpowered for 10 minutes before opening the instrument. This will allow any internal stored charge to discharge.

There are no user-adjustable internal circuits. For repairs other than fuse replacement, please contact Avtech (info@avtechpulse.com) to arrange for the instrument to be returned to the factory for repair. Service is to be performed solely by qualified service personnel.

 Caution: High voltages are present inside the instrument during normal operation. Do not operate the instrument with the cover removed.

RACK MOUNTING

A rack mounting kit is available. The -R5 rack mount kit may be installed after first removing the one Phillips screw on the side panel adjacent to the front handle.

ELECTROMAGNETIC INTERFERENCE

To prevent electromagnetic interference with other equipment, all used outputs should be connected to shielded loads using shielded coaxial cables. Unused outputs should be terminated with shielded coaxial terminators or with shielded coaxial dust caps, to prevent unintentional electromagnetic radiation. All cords and cables should be less than 3m in length.

MAINTENANCE

REGULAR MAINTENANCE

This instrument does not require any regular maintenance.

On occasion, one or more of the four rear-panel fuses may require replacement. All fuses can be accessed from the rear panel. See the “FUSES” section for details.

CLEANING

If desired, the interior of the instrument may be cleaned using compressed air to dislodge any accumulated dust. (See the “TOP COVER REMOVAL” section for instructions on accessing the interior.) No other cleaning is recommended.

WIRING DIAGRAMS

WIRING OF AC POWER

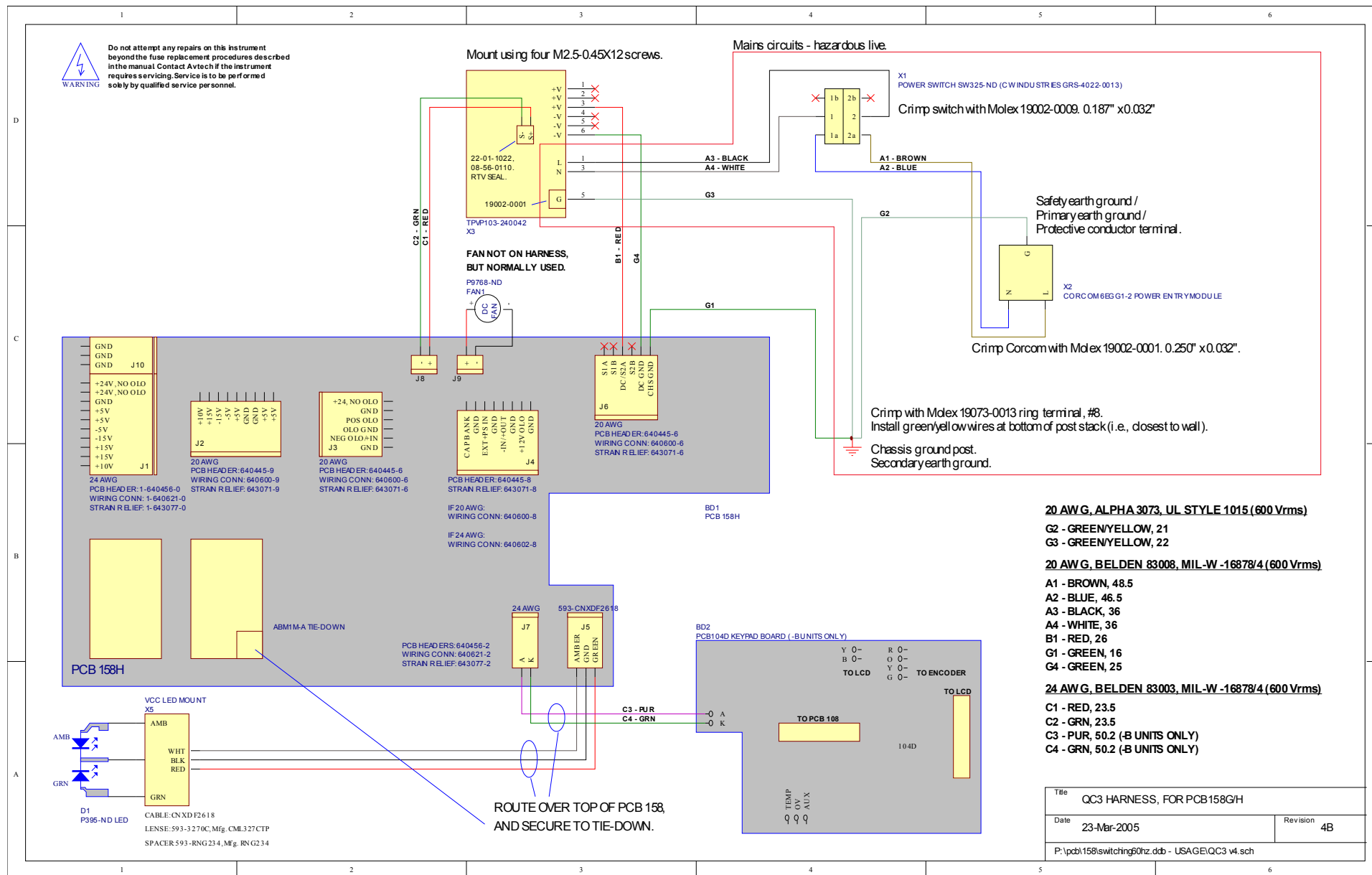

PCB 158H - LOW VOLTAGE DC POWER SUPPLY, 1/3

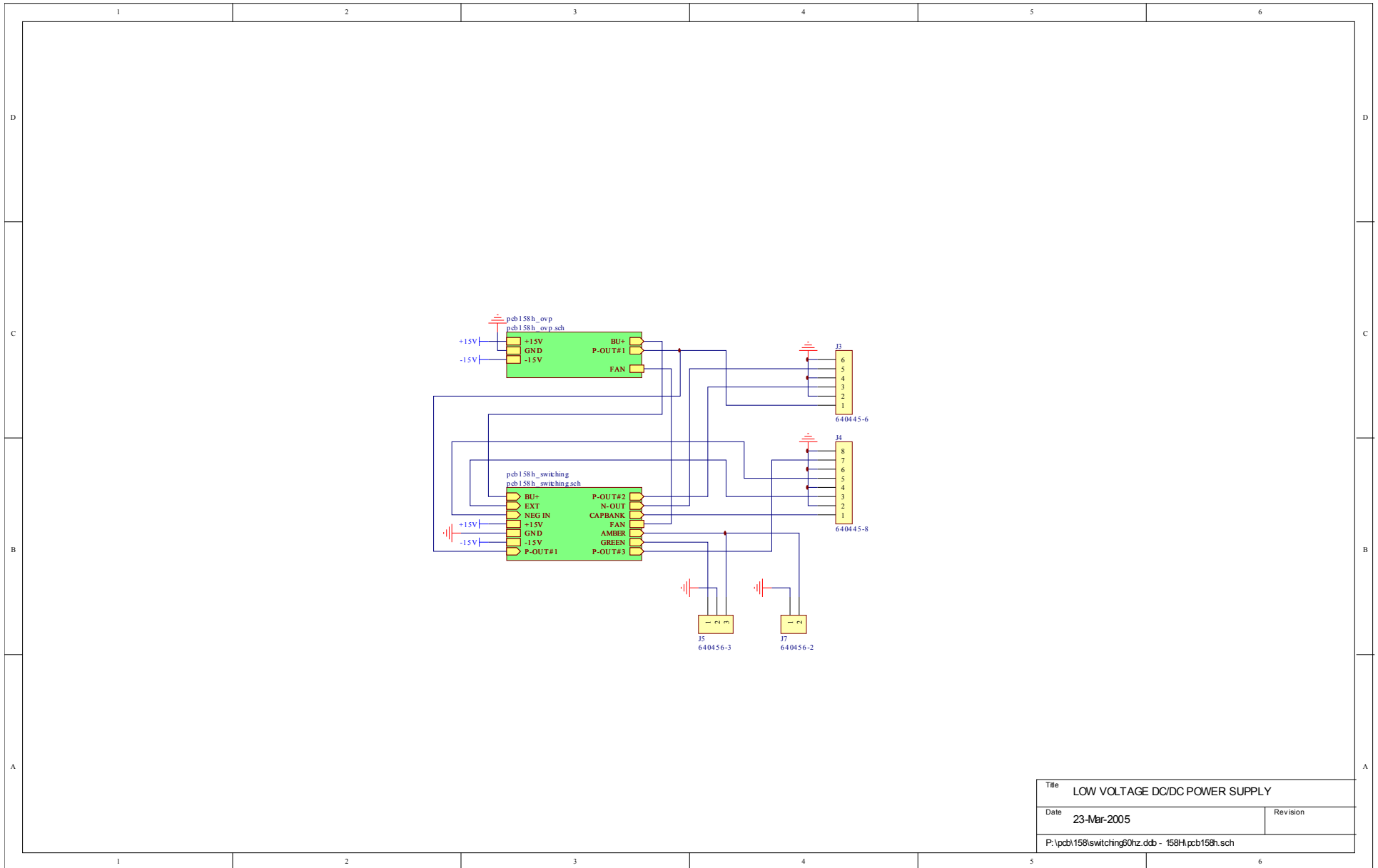

Title		LOW VOLTAGE DC/DC POWER SUPPLY
Date	23-Mar-2005	Revision
P:\pcb\158\switching60hz.ddb - 158H.pcb158h.sch		

PCB 158H - LOW VOLTAGE DC POWER SUPPLY, 3/3

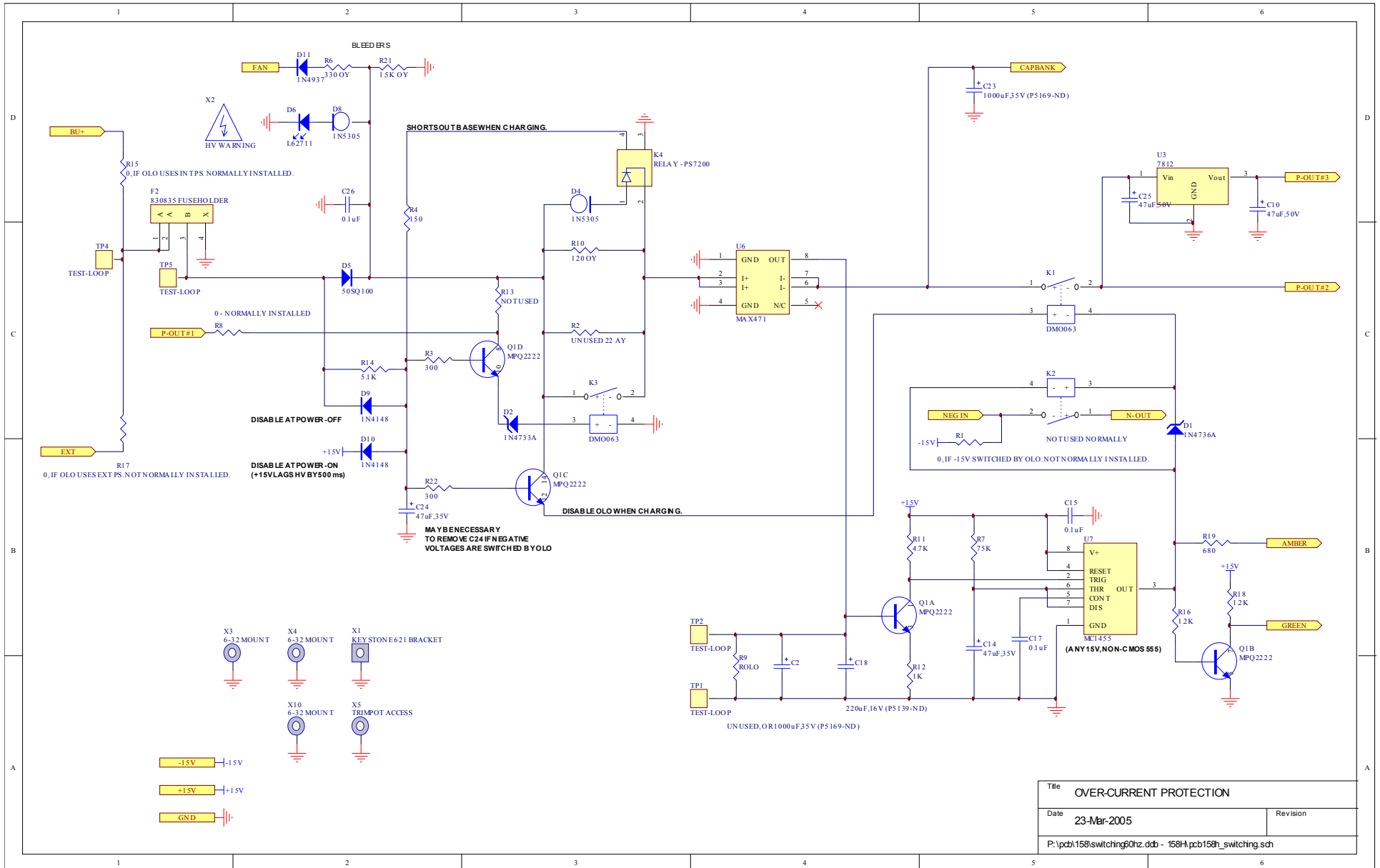

Title OVER-CURRENT PROTECTION	
Date 23-Mar-2005	Revision
P:\pcb\158\switching60hz.ddb - 158H.pcb\158h_switching.sch	

PCB 160B - HIGH VOLTAGE DC POWER SUPPLY

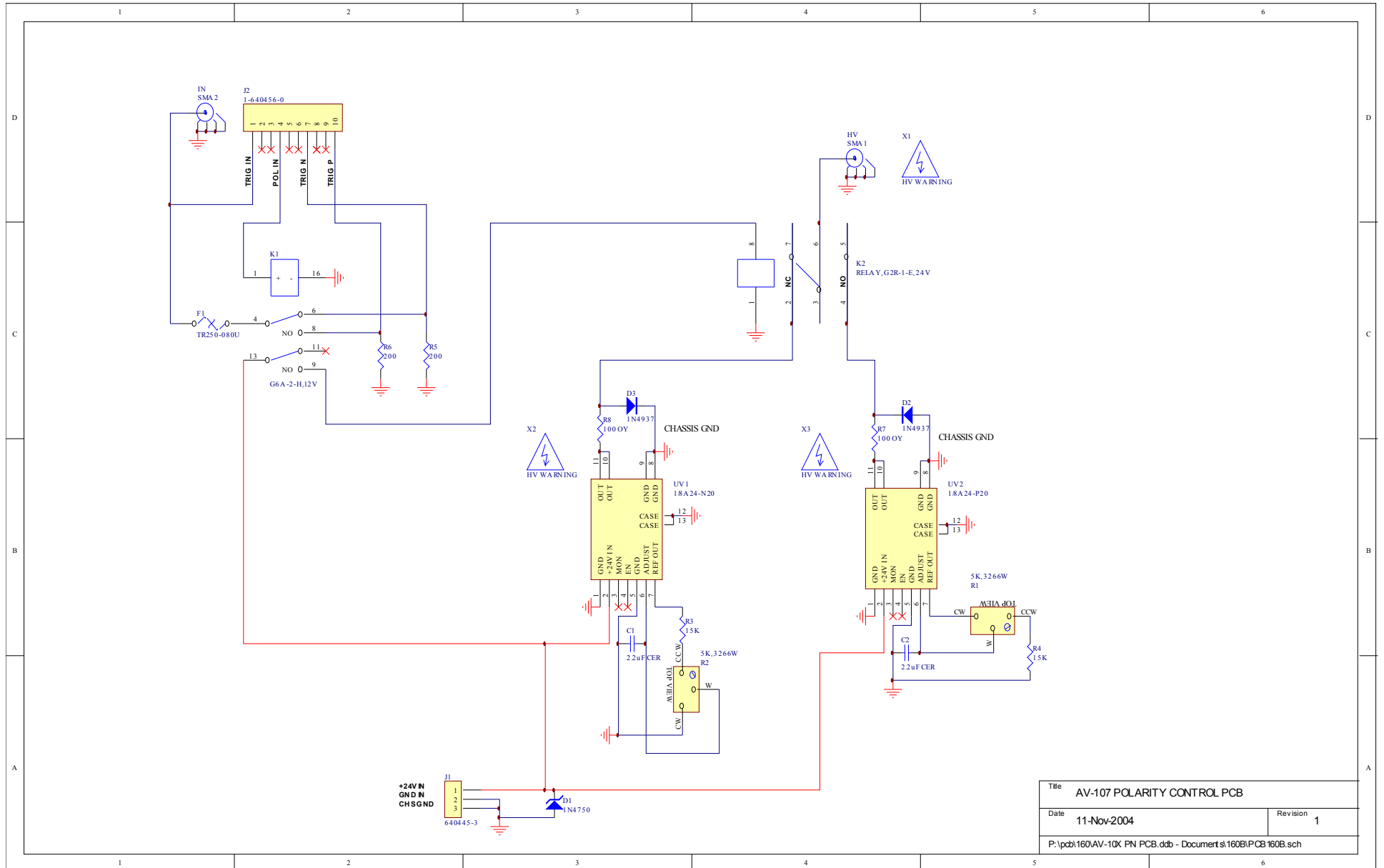

Title AV-107 POLARITY CONTROL PCB	
Date 11-Nov-2004	Revision 1
P:\pcb\160AV-10X PN PCB.dcb - Document\160B\PCB 160B.sch	

PCB 104D - KEYPAD / DISPLAY BOARD, 1/3

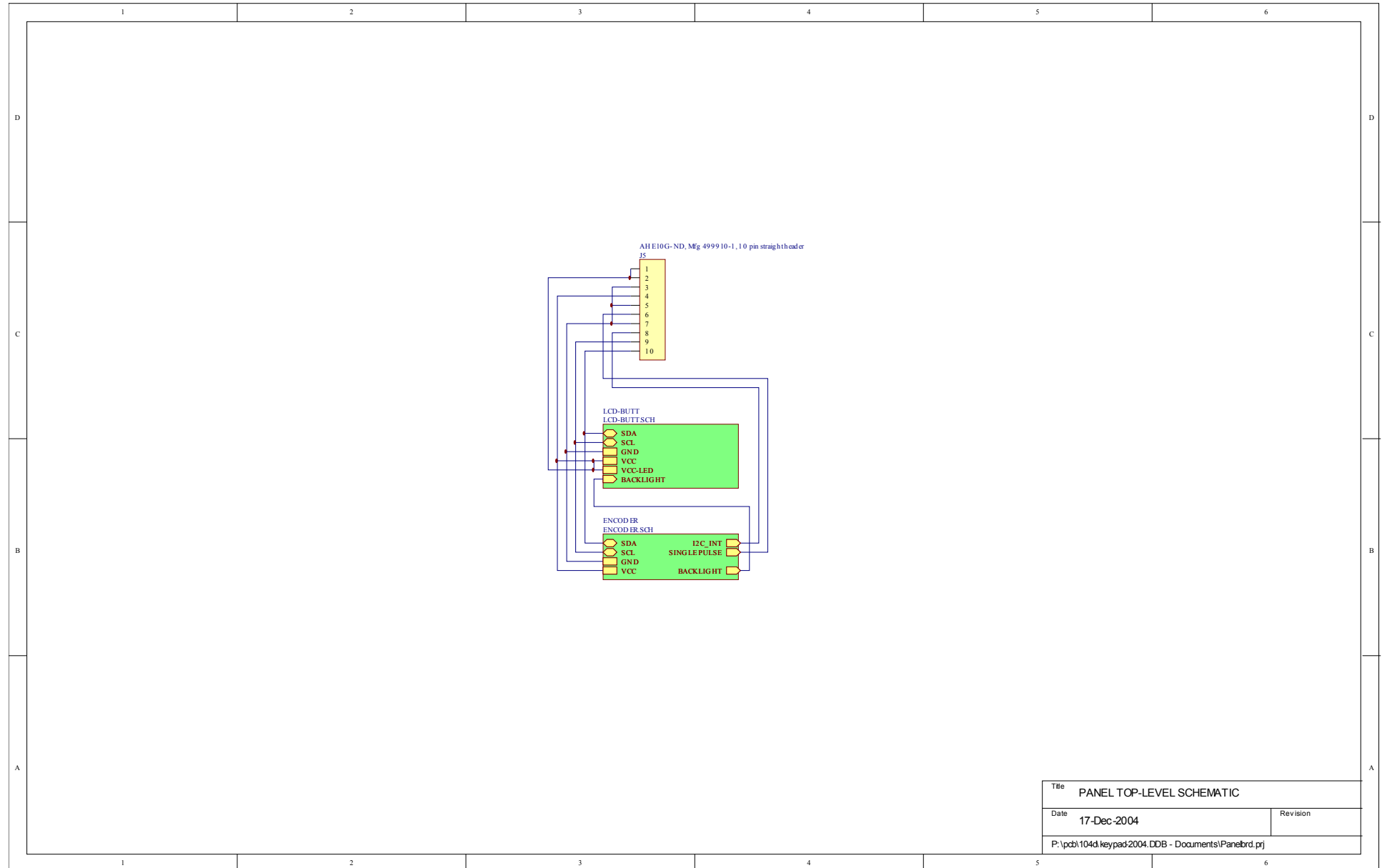

Title		PANEL TOP-LEVEL SCHEMATIC	
Date	17-Dec-2004	Revision	
P:\pcb\104d\keypad\2004.DDB - Documents\Panelbrd.prj			

PCB 104D - KEYPAD / DISPLAY BOARD, 2/3

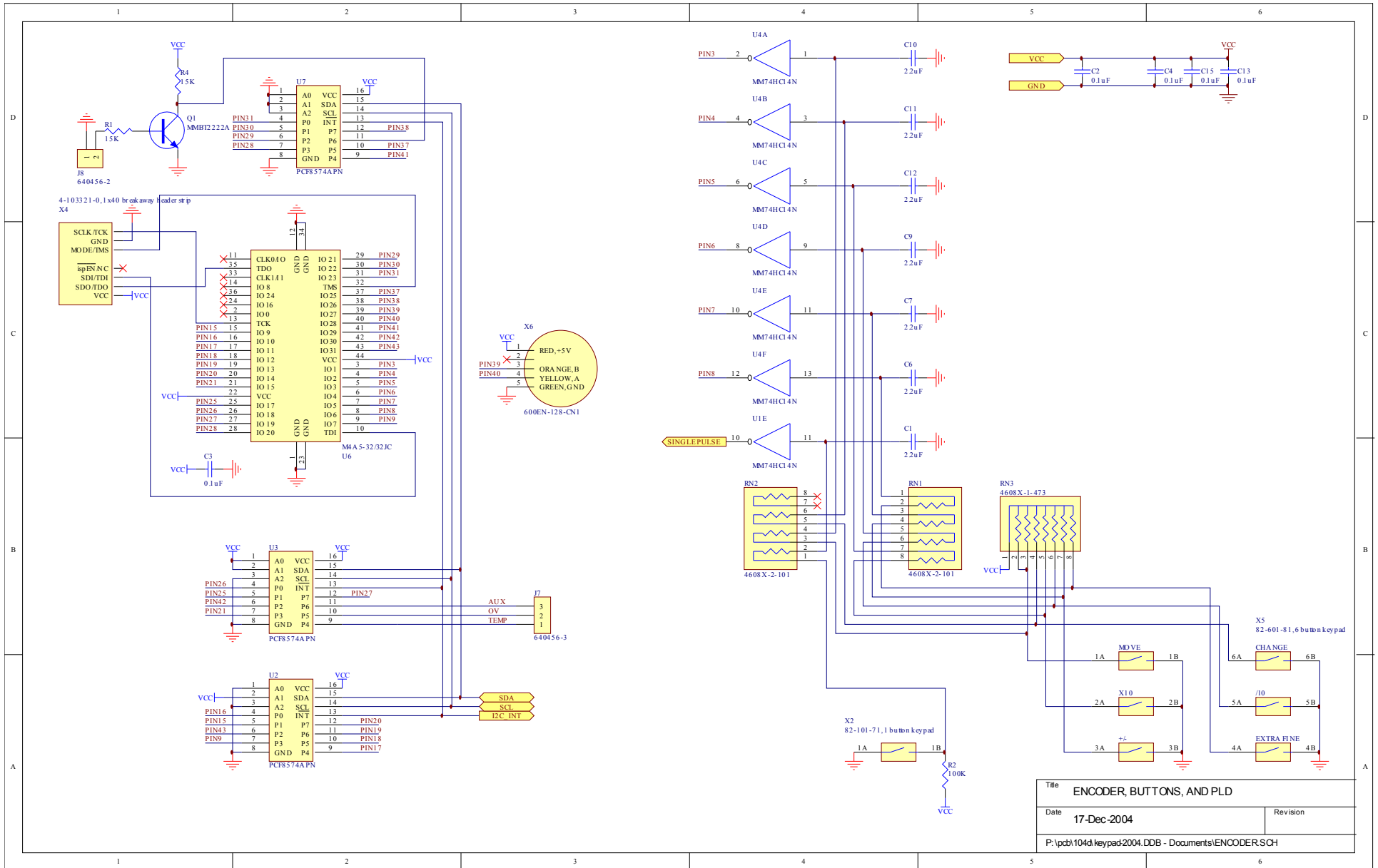

Title		ENCODER, BUTTONS, AND PLD
Date	17-Dec-2004	Revision
P:\pcb\104d\keypad\2004.DDB - Documents\ENCODER.SCH		

PCB 104D - KEYPAD / DISPLAY BOARD, 3/3

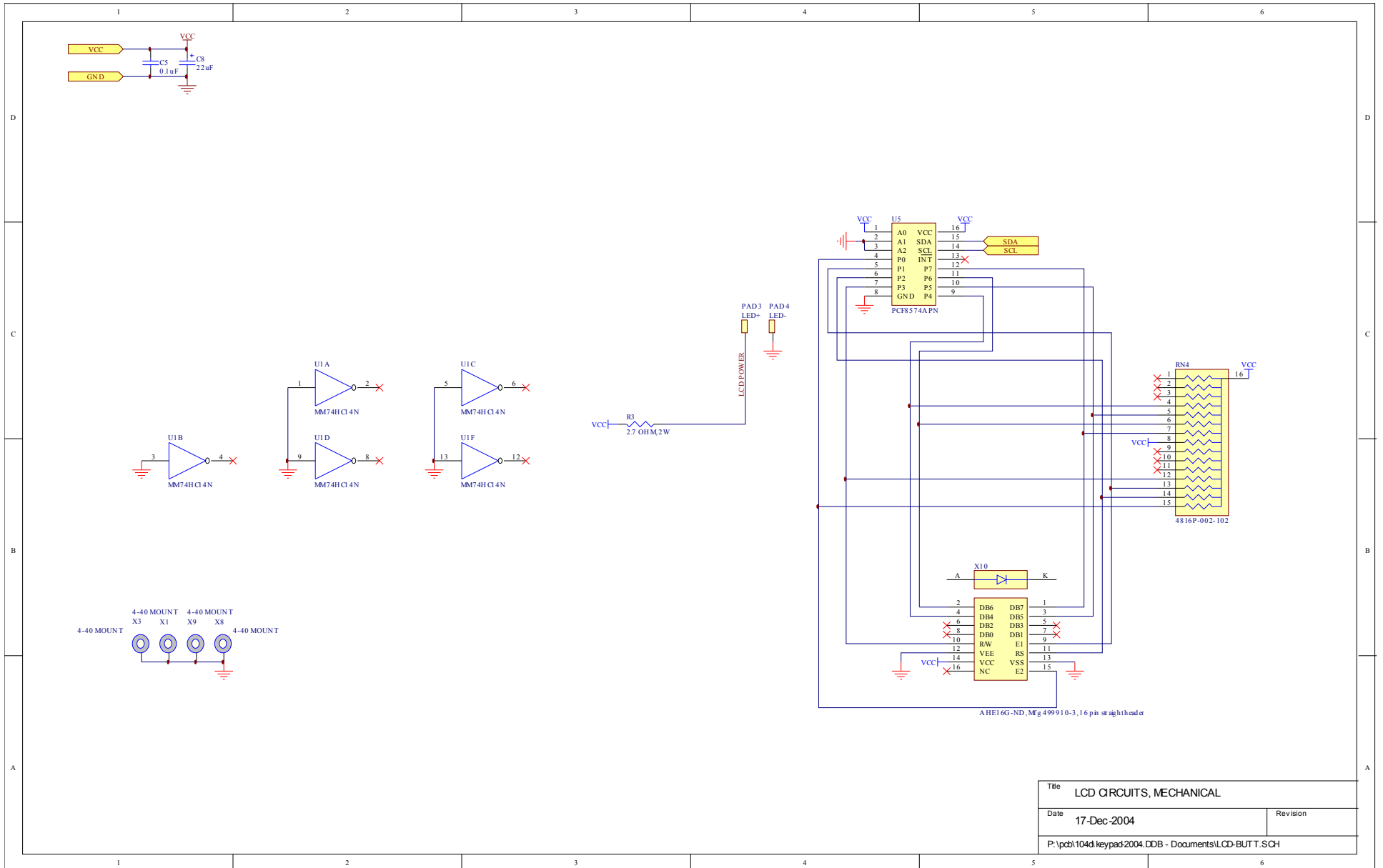

MAIN WIRING

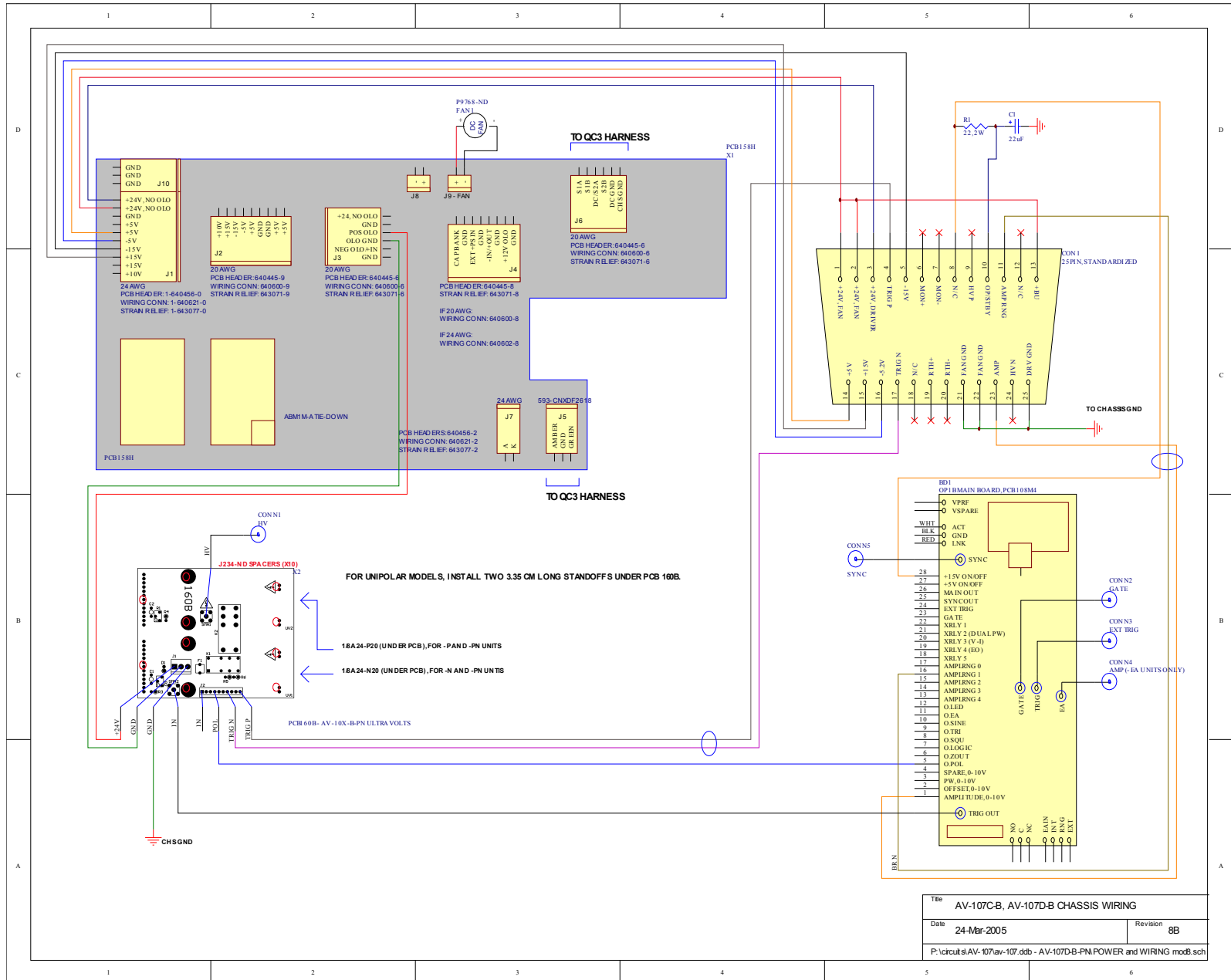

APPENDIX A - LOW-VALUE, LOW-INDUCTANCE, HIGH-POWER RESISTORS

The best approach for obtaining a low-value, low-inductance resistor is to connect many higher-value resistors in parallel. Connecting resistors in parallel reduces the total effective resistance and inductance.

Avtech does not recommend the use of single, high-power resistors, even if they are low-inductance types. These resistors experience high failure rates in pulsed applications.

SUPPLIERS

- Ohmite Mfg. Co.
3601 Howard Street
Skokie, IL 60076
Tel: (847) 675- 2600
Fax: (847) 675- 1505
www.ohmite.com

The Ohmite OY series of 2 Watt ceramic composition resistors are extremely rugged and well suited to pulsed applications. Use many (i.e., >10) of these resistors in parallel to construct a high-current, high-power, low-inductance load.

These resistors are readily available from Digi-Key (www.digikey.com).

- RCD COMPONENTS INC.
520 East Industrial Park.,
Manchester, NH USA 03109- 5316
Tel: (603) 669-0054
Fax: (603) 669-5455
www.rcd-comp.com

The RCD RSF2B series of 2 Watt ceramic composition resistors are rugged and well suited to pulsed applications (although not as well suited as the Ohmite OY series). Use many (i.e., >10) of these resistors in parallel to construct a high-current, high-power, low-inductance load.

PERFORMANCE CHECK SHEET